

SE03-DT - Replacement Parts

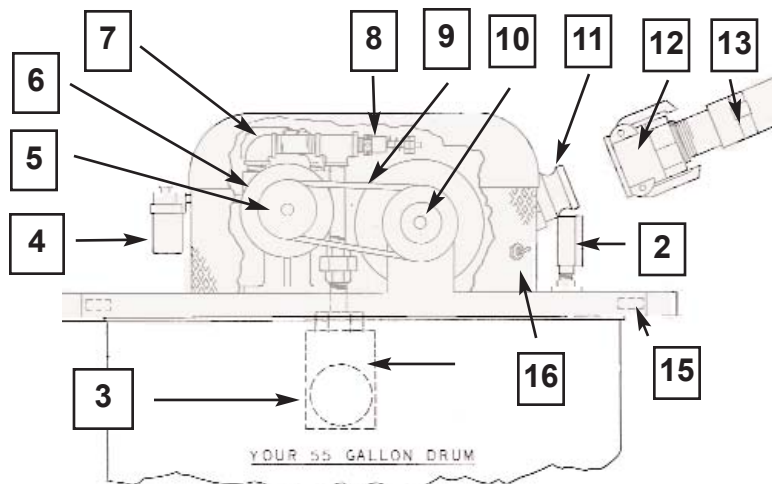

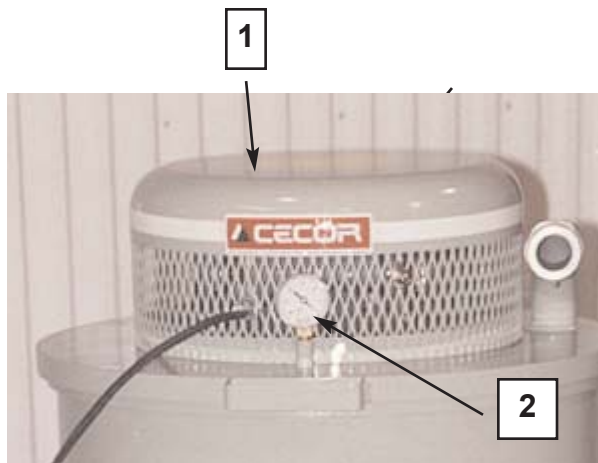







SE03-DT ELECTRIC DRUM-TOP SUMP CLEANER

| | | | |
|---|---|-----------|------------------------------|
| 1 | <i>Not pictured</i> | A-210-675 | Cover Assembly |
| 2 |  | SP-194A | Vacuum Gage, 2" |
| 3 |  | A-210-402 | Float Control Assembly, 3/4" |
| 4 |  | SP-214 | Oiler, Wick Type |
| 5 |  | SP-207 | Pump Pulley |
| 6 |  | SP-209 | Fan Impeller |
| 7 |  | SP-211 | Muffler |
| 8 |  | SP-182 | Vacuum Relief Valve, 3/8" |
| 9 |  | SP-213 | V-Belt, 20" |



SE03-DT - Replacement Parts

| | | | |
|----|---|-----------|---|
| 10 |  | SP-208 | Motor Pulley |
| 11 |  | SP-405 | Disconnect Adapter, 1-1/2" Female Threads, A |
| 12 |  | SP-404 | Disconnect Coupler, 1-1/2" Female Threads, D |
| 13 |  | A-220-144 | Sump Cleaner Hose Assembly, Clear, 1-1/2" x 10' long |
| 14 |  | A-220-142 | Optional Sump Cleaner Hose Assembly, Clear, 1-1/2" x 16' long |
| 15 |  | A-210-106 | Drum Lid Gasket |
| 16 |  | SP-154 | Switch |
| 17 |  | A-210-474 | Straight Nozzle (fits 1-1/2" I.D. hose) |
| 18 |  | A-220-149 | Flare Nozzle assembly (fits 1-1/2" I.D. Hose) |
| 19 |  | A-220-150 | Flexible Nozzle Assembly (fits 1-1/2" I.D. Hose) |
| 21 |  | SP-370 | Coupler Gasket, 1-1/2" |
| 22 |  | SP-227B | Vacuum Pump Assembly, Model 0740-V2 |

SE03-DT ELECTRIC DRUM-TOP SUMP-CLEANER



SE03-DT - Accessories



**TX-55PL
Drum Tank**

CECOR's heavy duty 55-gallon drum tank, made of heavy gauge steel, is stronger than a standard 55 gallon drum. The tank is mounted on four casters for easy rolling and maneuverability. Fork pockets built into the base provide easy handling by fork truck. The tank features an 8" x 10" cleanout door for removing settled solids. Valve in door permits fluid to drain out, leaving the solids.

Drum Dolly



The drum dolly puts wheels under your own 55 gallon drum. Heavy frame construction with two rigid and two swivel casters with 4" diameter phenolic roller-bearing wheels. Simple T-grip handle provides maneuverability and pulling ease.

