

Trash Trucks

TA-318
TA-327

TA-340
DA-254

CECOR Trash Trucks are designed for collecting and hauling bulky, light density loads. With a relatively small footprint these trash trucks park where scrap is being produced.

Tough enough for use in the factory, these carts come in 18, 27 and 40 cubic foot capacity. The DA-254 is fitted with dumping trunnions for elevated dumping from fork lift or hook hoist.



TA-340-6R

Optional tow link is available on models TA-318, TA-327 and TA-340 for towing in trains.

- **Rugged all-metal construction with fully-welded leak-proof seams.**
- **6 inch industrial casters.**
- **TA Series feature reinforced dumping knees for complete, controllable manual emptying at floor or dock level.**
- **Extremely maneuverable, even when fully loaded.**
- **Available options include tow link, and separate hinged cover.**



TA-327-6R

Ergonomic design features controllable two-stage dumping action.

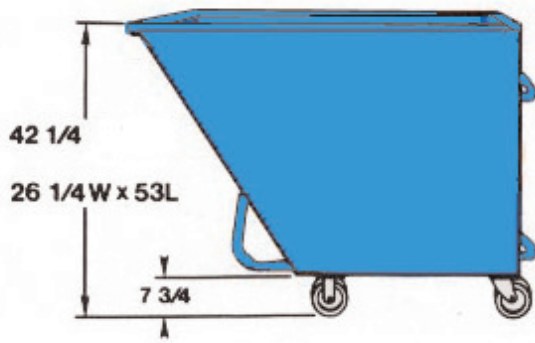

TA-318

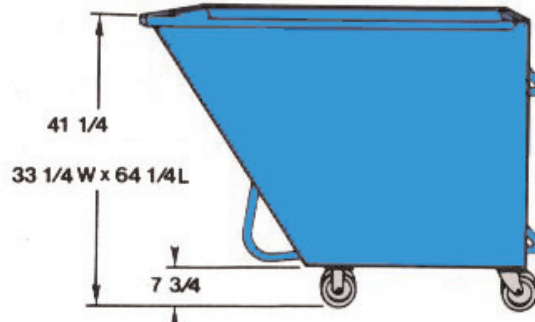

TA-327

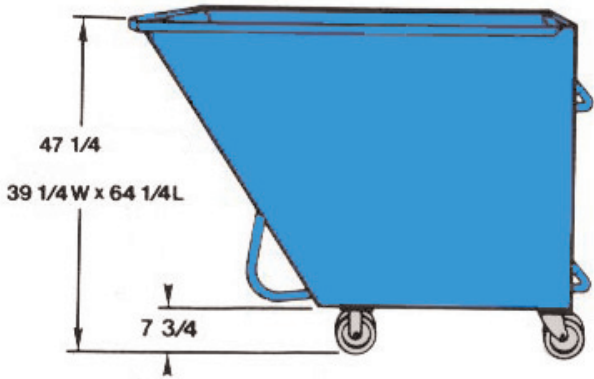

TA-340

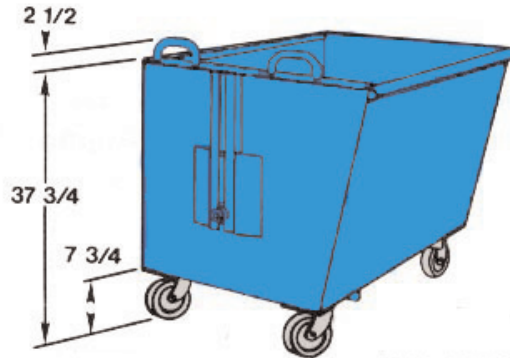

DA-254

	TA-318	TA-327	TA-340	DA-254
Capacity	18 cubic feet	27 cubic feet	40 cubic feet	27 cubic feet
Load Rating	360 lbs.	540 lbs.	800 lbs.	800 lbs.
Bin Length	48" long	59-1/4" long	59-1/2" long	48" long
Bin Width	24" wide	30" wide	36" wide	36" wide
Bin Depth	34-1/2" deep	33-1/2" deep	39-1/2" deep	30" deep
Color	Blue standard Gray optional	Blue standard Gray optional	Blue standard Gray optional	Blue standard Gray optional
Lip Height	42-1/4"	41-1/4"	47-1/4"	37-3/4"
Shipping Weight	150 lbs.	192 lbs.	261 lbs.	302 lbs.

NOTE: Engineering specifications subject to change without notice.



CECOR

102 Lincoln St. Verona, WI 53593 1-800-356-9042 Fax: 608-845-6792
E-mail: cecor@cecor.net Website: www.cecor.net